



Product Parameters and Specifications
Model: Legatia L1V2 Tweeter

Legatia™ L1V2

The Legatia™ L1V2 is a new offering from Hybrid Audio Technologies as of December 2008. The Version 2 Legatia L1 tweeter (denoted as “L1V2”) contains several important upgrades over the already imminently successful Legatia L1 tweeter.

The L1V2 is a compact, high-resolution 20mm soft-dome tweeter driver that can be used for the reproduction of treble frequencies in dedicated two-, three-, and four-way front stage systems. We are proud to be one of the very few speaker manufacturers that understand what it takes to build a car audio tweeter: larger diaphragm tweeters sound heavy and unremarkable, lack detail and have unnaturally fast roll-off in the upper treble frequencies, have undesirable polar response, and are extremely difficult to install. Additionally, metal dome tweeters tend to be harsh, brittle, and add unnecessary coloration to the music. This is why we have built the quintessential small-diameter car audio tweeter that is very easy to install, boasts a small diameter soft-dome silk diaphragm and resonance frequency that is complementary to all types of front-stage system architecture. The L1V2 can be listened to for hours without listener’s fatigue, while having an industry-standard polar response. Tweeters were meant to play treble, and ours does it effortlessly, in a package that fits easily in the palm of your hand.



Photo 1: L1V2 tweeter, shown larger than actual size for detail

Legatia L1V2 in more detail

The Legatia L1V2 is a 20mm (3/4-inch) dome-type tweeter which has a very good, extended linear response and exceptional transient response. The design offers a wide dispersion pattern for flexible mounting locations and easy installation. And the phase linearity of the design ensures phase coherent imaging and staging cues in the car audiophile system.

The L1V2 starts with an impregnated fine silk cloth dome diaphragm for a linear tonal character, with a treated silk surround to damp edge modes and resonances. The L1V2 is efficient, exhibits low distortion, and has a wide dispersion. The dome is of extremely low mass and is much less



Product Parameters and Specifications

Model: Legatia L1V2 Tweeter

susceptible to mechanical deformation than other designs, and yet yields a smooth response over the extent of its range.

The motor assembly of the L1V2 is conventional dynamic, with a $\phi 19.5 \times 3$ H NdFeB neodymium magnet to ensure a small footprint size and shallow depth. The L1V2 tweeter has a resonance frequency of 1,830 Hz, providing a considerable amount of flexibility for use with Legatia midbass drivers in point-source two-way front stage systems, as well as continuing to be the tweeter of choice of point-source Hybrid Audio Technologies three-way and four-way front stage kits. The power handling was doubled from the original L1 tweeter, and the L1V2 has a nominal resistance of 4 ohms.

As mentioned previously, the dome is a fine silk diaphragm that has an acoustically transparent, perforated steel grille to protect it. A major upgrade over the original L1 is a fully-machined aluminum body and mounting flange to effectively damp dome modes, reduce dome resonance, and edge distortion. The mounting flange accommodates three screws for surface-mounted installation; black anodized Alan-head screws are included with each tweeter kit. The L1V2 tweeter comes in two colors to ensure cosmetic integration with the vehicle's surroundings: silver brushed aluminum, and anodized black (there is no cost difference between the two colors). Please reference Figure 2:



Figure 2: L1V2 tweeter pair, shown in optional black anodized color

Another upgrade over the original L1 tweeter is the inclusion of an extruded polypropylene cap with integrated high-end nickel-plated spring-loaded push terminals at the rear of the tweeter's motor assembly. The spring-loaded terminals give the end-user flexibility in direct connection with large-gauge tinned wiring, without the need for crimp terminals. The overall dimensions of the driver are very amenable for use in the car audio environment, boasting a depth of just 20mm, for the ultimate in mounting flexibility. Reference Figure 3, below, for the mechanical drawing of the L1V2 tweeter:



Product Parameters and Specifications
Model: Legatia L1V2 Tweeter

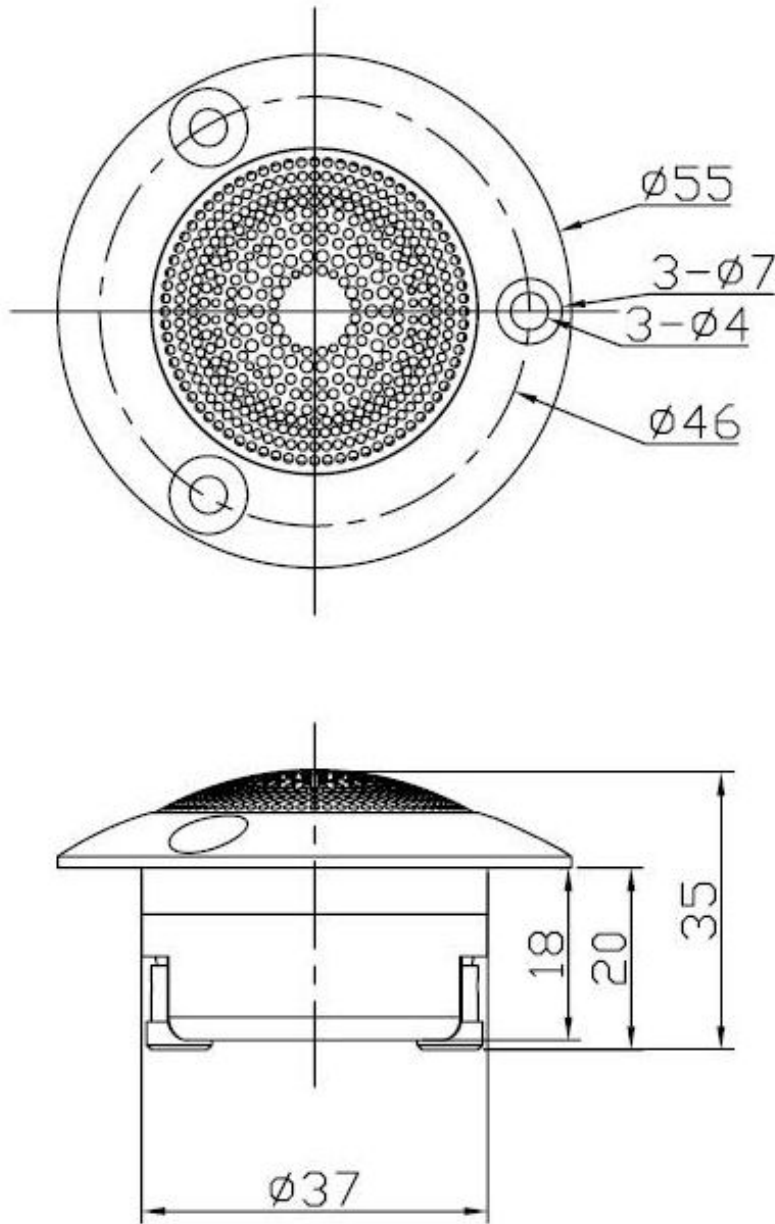

Figure 3: L1V2 tweeter - dimensioned mechanical drawing



Product Parameters and Specifications
Model: Legatia L1V2 Tweeter

Legatia L1V2 Thiele-Small Parameters

Overall Diameter	φ55 mm
Mounting Depth	20 mm from bottom of surface-mount flange to bottom of open (non-wired) terminals
Mounting Methodology	Surface-mount tweeter with three 3mm screw holes to secure the tweeter body from the front
Construction	Solid machined aluminum with integrated polypropylene rear cap and push terminals
Distortion	<5% max at rated power input, no crossover
Magnet Diameter and Construction	φ19.5 × 3 H NdFeB
Recommended Minimum Crossover Frequency	3,200 Hz at 24 dB/octave highpass
P _{nom} : Rated Power Input (No Crossover)	10 watts (AES Standard)
P _{max} : Maximum Power Input (No Crossover)	20 watts (AES Standard)
P _{max} (With Recommended Minimum Crossover)	75 watts
Resonance Frequency (Fs)	1,830 Hz
Frequency Range	2,500 Hz - 25,000 Hz, +/- 3 dB
Sensitivity	90 dB at 1 watt/1meter
Nominal Impedance	4Ω
DC Resistance	3.2Ω
Voice Coil Diameter	20 mm (3/4-inch)
Q Mechanical System (Qms)	3.103
Q Electrical System (Qes)	3.553
Q Total System (Qts)	1.656
K _{rm}	198.84 nΩ
E _{rm}	1.278
K _{xm}	2.136 mH
E _{xm}	0.513



Product Parameters and Specifications
Model: Legatia L1V2 Tweeter

Legatia™ L1 Impedance and SPL Verses Frequency Plots

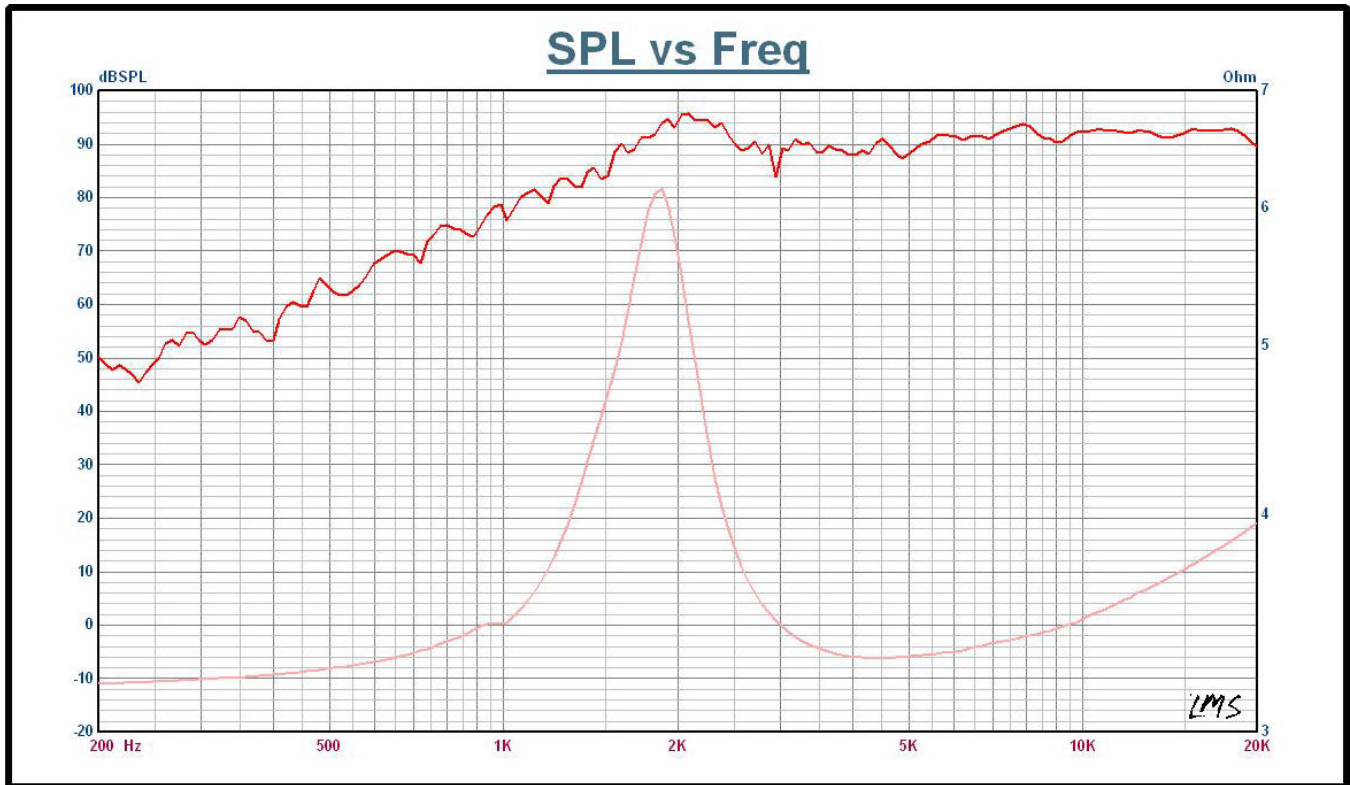

Annex 1: Legatia L1V2 3-Dimension Design Drawings (without rear cap tooling)

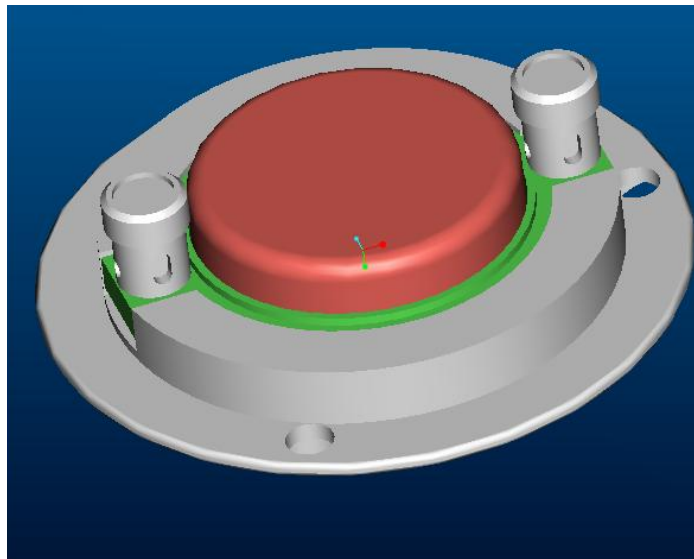
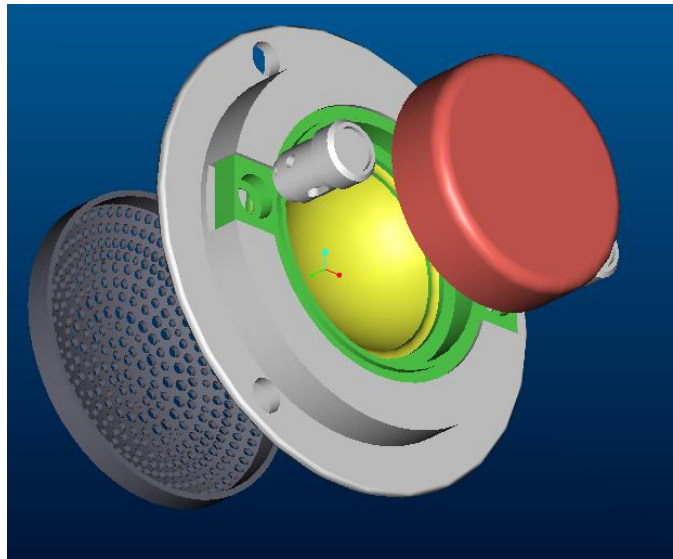
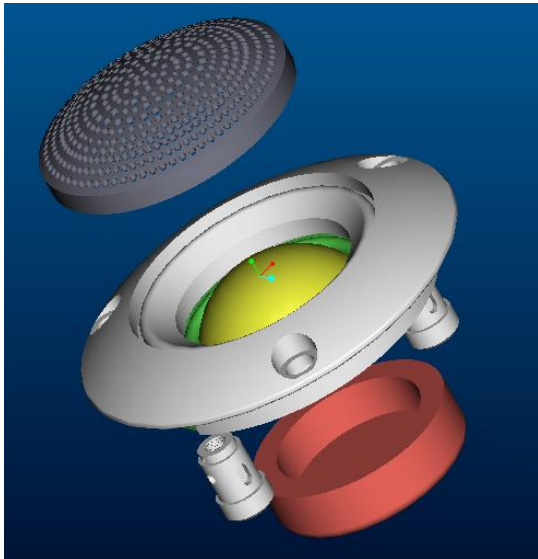



Product Parameters and Specifications

Model: Legatia L1V2 Tweeter

Annex 2: Legatia L1V2 3-Dimension Design Drawings (with rear cap tooling)

